

MP Series Reverse Osmosis Systems



Water Techniques MP Series Reverse Osmosis/Activated Carbon Water Purification System is designed for light commercial applications where higher water production is required. Constructed of lead-free, corrosion proof NSF and FDA compliant materials, the MP Series will produce up to 200 gallons per day of purified water. Additional features include:

- High Output, Cost Effective Thin Film Composite Membrane
- Quiet, Reliable Operation
- Available with exclusive Permeate Pump for higher storage tank and delivery pressure
- Each System Factory Tested and Sanitized
- Available with 10" or 20" Pre-filtration Assembly

Reverse Osmosis/Activated Carbon

Developed in the 50's to de-salinate sea water, Reverse Osmosis Membrane Separation Technology is widely recognized as the most effective method for the removal of mineral salts (TDS), heavy metals and organic chemicals from water. Dollar for dollar, no other water treatment method can remove the broad spectrum of contaminants and provide the overall water quality of a Reverse Osmosis System.

The LP 100's exclusive Five Stage Process includes the following:

Stage 1: Sediment Pre-filtration - Graded density filter removes dirt, rust and sediment; particles 10 times smaller than the human eye can see.

Stage 2: Block Carbon Pre-filtration - Two extruded block carbon filters for increased contact time remove chlorine and other related chemicals.

Stage 3: Ultrafiltration - Physically removes microscopic particles as small as 2 millionths of an inch.

Stage 4: Reverse Osmosis - Effectively removes Total Dissolved Solids (TDS), metals and salts like lead and sodium.

Stage 5: Block Carbon Post-filtration - Final polishing to assure the highest quality water possible.

The Professional's Choice for the following applications and more!

- ▶ Drinking Water
- ▶ Office Systems
- ▶ Residential Multi Points of Use
- ▶ Beverage Equipment
- ▶ Laboratory Water
- ▶ Commercial Icemakers
- ▶ Battery Fill
- ▶ Spot Free Rinse
- ▶ Ingredient Water
- ▶ DI Pretreatment
- ▶ Automatic Fill Coffee Makers
- ▶ Steam Equipment

MP Series Specifications

Model Number	MP-200-10H & S	MP 200-20H & S
Membrane Type	Thin Film Composite	Thin Film Composite
Operating Pressure	100 PSI	100 PSI
Percent Recovery	MP-200-10H 25% to 30%	MP-200-20H 25% to 30%
	MP-200-10S 50%	MP-200-20S 50%
Typical TDS Rejection	97%	97%
Feed Temperature	40 - 100 Degees F	40 - 100 Degees F
Feed Pressure	20 - 85 psi	20 - 85 psi
Feed pH	4 to 11	4 to 11
Feed TDS	Up to 1500	Up to 1500
Production	200 Gallons Per Day	200 Gallons Per Day
Electrical	24 VAC	24 VAC
Motor	Permanent Magnet	Permanent Magnet
Pump	3 Chamber Diaphragm	3 Chamber Diaphragm
Weight	33 lbs.	38 lbs.
Dimensions	21L x 9W x 16H	22L x 9W x 26H

MP-200-10/H & S

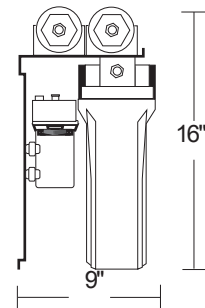
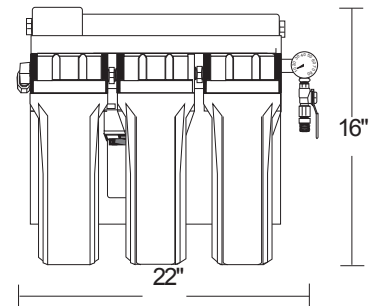

MP-200-20/H & S

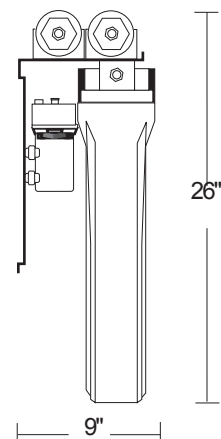
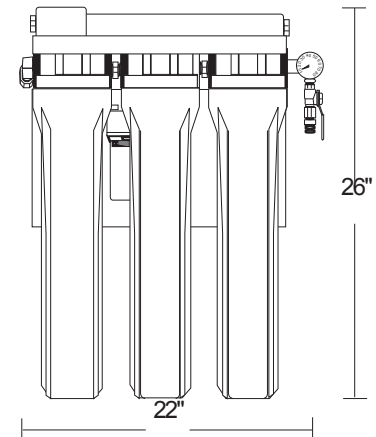

Feed Conditions: Manganese, Hydrogen Sulfide, Iron and other potential foulants should be removed from feed water supply prior to prefilters.

Models MP 200-10S and MP 200-20S, feed water must be softened prior to prefilters.

Models MP 200-10H and MP 200-20H, water hardness must be below 20 grains per gallon

Designed and manufactured exclusively for:

Water Techniques

1815 E. Wilshire Avenue #912, Santa Ana, CA 92705
 Phone 714-384-4500, Fax 714-384-4505