

## LP Series Reverse Osmosis Systems



Water Techniques LP Series Reverse Osmosis/Activated Carbon Water Purification System is designed for light commercial applications where higher water production is required. Constructed of lead-free, corrosion proof NSF and FDA compliant materials, the LP Series will produce up to 100 gallons per day of purified water. Additional features include:

- High Output, Cost Effective Thin Film Composite Membrane
- Quiet, Reliable Operation
- Available with exclusive Permeate Pump for higher storage tank and delivery pressure
- Each System Factory Tested and Sanitized
- Available with 10" or 20" Pre-filtration Assembly

### Reverse Osmosis/Activated Carbon

Developed in the 50's to de-salinate sea water, Reverse Osmosis Membrane Separation Technology is widely recognized as the most effective method for the removal of mineral salts (TDS), heavy metals and organic chemicals from water. Dollar for dollar, no other water treatment method can remove the broad spectrum of contaminants and provide the overall water quality of a Reverse Osmosis System.

The LP 100's exclusive Five Stage Process includes the following:

**Stage 1: Sediment Pre-filtration** - Graded density filter removes dirt, rust and sediment; particles 10 times smaller than the human eye can see.

**Stage 2: Block Carbon Pre-filtration** - Two extruded block carbon filters for increased contact time remove chlorine and other related chemicals.

**Stage 3: Ultrafiltration** - Physically removes microscopic particles as small as 2 millionths of an inch.

**Stage 4: Reverse Osmosis** - Effectively removes Total Dissolved Solids (TDS), metals and salts like lead and sodium.

**Stage 5: Block Carbon Post-filtration** - Final polishing to assure the highest quality water possible.

### The Professional's Choice for the following applications and more!

- ▶ Drinking Water
- ▶ Office Systems
- ▶ Residential Multi Points of Use
- ▶ Beverage Equipment
- ▶ Laboratory Water
- ▶ Commercial Icemakers
- ▶ Battery Fill
- ▶ Spot Free Rinse
- ▶ Ingredient Water
- ▶ DI Pretreatment
- ▶ Automatic Fill Coffee Makers
- ▶ Steam Equipment

## LP Series Specifications

Model Number	LP-45-10H & S	LP 100-20H & S
Membrane Type	Thin Film Composite	Thin Film Composite
Operating Pressure	Municipal Line Pressure	Municipal Line Pressure
Percent Recovery	LP-45-10H 25% to 30%	LP-100-20H 25% to 30%
	LP-45-10S 50%	LP-100-20S 50%
Typical TDS Rejection	97%	97%
Feed Temperature	40 - 100 Degees F	40 - 100 Degees F
Feed Pressure	20 - 85 psi	20 - 85 psi
Feed pH	4 to 11	4 to 11
Feed TDS	Up to 1500	Up to 1500
Production	Up to 45 Gallons Per Day	Up to 100 Gallons Per Day
Weight	33 lbs.	38 lbs.
Dimensions	14L x 5W x 16H	16L x 5W x 26H

LP-45-10H & S

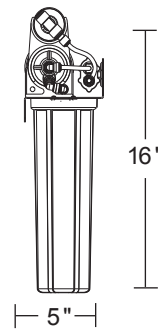
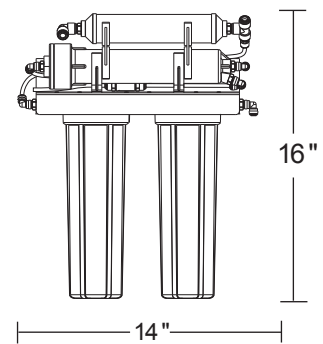

LP-100-20H & S

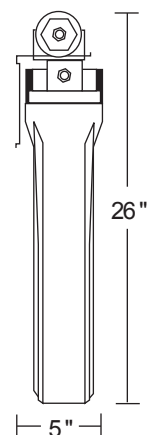
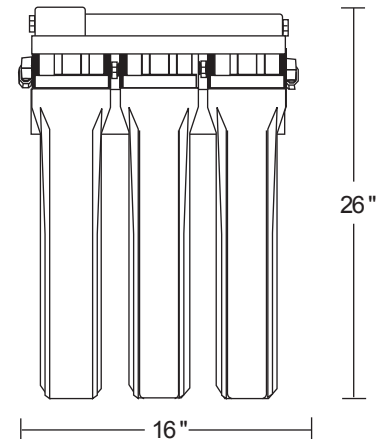

Feed Conditions: Manganese, Hydrogen Sulfide, Iron and other potential foulants should be removed from feed water supply prior to prefilters.

Models LP 45-10S and LP 100-20S, feed water must be softened prior to prefilters.

Models LP 100-10H and LP 100-20H, water hardness must be below 20 grains per gallon

Designed and manufactured exclusively for:

***Water Techniques***

2915 Daimler Street, Santa Ana, CA 92705  
Phone 714-384-4500, Fax 714-384-4505